

ZENOIS

IMPLANT SYSTEM

种植体

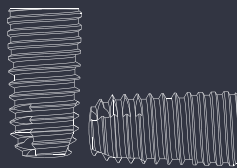



ZENOIS

Zenith Osseointegration Implant System

ZENOIS
IMPLANT SYSTEM

ZENOIS 种植体系统

地址：光州广域市 北区 尖端科技路 333,110
(大村洞, 事业化3洞)

电话：+82-70-5178-1958

传真：+82-70-4855-2609

网址：www.icmimplant.com

邮箱：master@icmimplant.com

ZENOIS IMPLANT SYSTEM

#110, Commercialization Building 3 dong, 333
Cheomdangwagiro, Buk-gu, Gwangju, KOREA

Tel：+82-70-5178-1958

Fax：+82-70-4855-2609

Web：www.icmimplant.com

Email：master@icmimplant.com

Contents

ZENOIS History
ZENOIS Design concept
ZENOIS Flow Chart

FIXTURE

ZENOIS Fixture.....07

Cover Screw&Healing

Cover Screw.....08

Healing Abutment.....08

Impression Coping

Impression Coping.....10

Analog

Analog Abutment.....10

UCLA Abutment

CCM Autment.....11

Over Denture

O-ring Abutment.....12

Abutment

Mount Autment.....12

Milling Autment-Two piece.....13

Angled Autment-Two piece.....14

Rigid Autment-One piece.....15

Cemented Autment-Two piece.17

Plastic Autment.....21

Surgical Kit.....22

ZENOIS

IMPLANT SYSTEM

ZENOIS is an expert company for dental implants.
We export many countries such as China, Japan, USA, Mexico, Iran and etc.
ZENOIS has developed and produced all kinds of dental implants like fixture, abutment, analog and etc. we manufacture orthodontic screw and mini implant.
ZENOIS can provide various kinds of dental products with you and satisfy your needs.
Our strength is to supply the highest quality products at an competitive price.
ZENOIS will continually focus on enhancing the world best quality.

ZENOIS 是于2007年成立的全球化医疗器械专业制造企业, 基于打造世界最高品质的公司信念, 为了持续地改善品质, ZENOIS 努力通过研究和开发, 为增进人类的健康而付诸全力。

ZENOIS 通过持续的研究人力投资 构筑了R&D中心 主导着各种新产品的开发, 并于2008年获得风险企业认证和 FDA 501(K)。

此外, 作为全球化医疗器械专业制造企业, ZENOIS 还面向美国、墨西哥、欧洲和亚洲等全世界20多个国家生产和出口牙科用种植体、牙科用材料和一般医疗器械等。

ZENOIS 通过不断的研究开发和革新保证最高的品质, 为了客户的感动而全力以赴。

谢谢。

ZENOIS

IMPLANT SYSTEM

ZENOIS COLOR CODES

With color codes it is easy to identify the implant's diameter.



Body Thread_____

Double Thread is Reduced operating hours
Sharp shape that is easy to cool with a rigid bone.
Based on bone variable thread depth, has stable fixation

Cutting Edge_____

Using the helical cutting edge, improving self tapping ability
Differentiating blade parts according to diameter,
Equalize the support force of the outer diameter screw part

Apex_____

Dome-type Design Advantages for Sinus Evaluation

Platform Switching_____

Bone Loss is Prevention

Surface_____

RBM Surface treatment : stable osteopor

Tapered Body_____

Ensures that weak fractures maintain good initial stability
Open Thread use, easy to adjust the depth of fit

容易修正植入路径

良好的初期固定力，上·下颌都可以即刻负重

11锥形内接六角连接埋入式种植体

骨等级（埋入式）种植体

0.85mm间隔的设计，是考虑到植入速度和负荷度来设计的，这是为了骨形成最理想的构造
切边具有良好的自攻螺纹能力

Submerged type implant with an Internal HEX & 11°
Morse Taper connection structure

Increased osseointegration in the cortical bone

Decreased marginal bone loss

Widened thread and double-tapered shape enable excellent initial bonding stability with soft bone
Balanced cutting edge with excellent self-tapping force

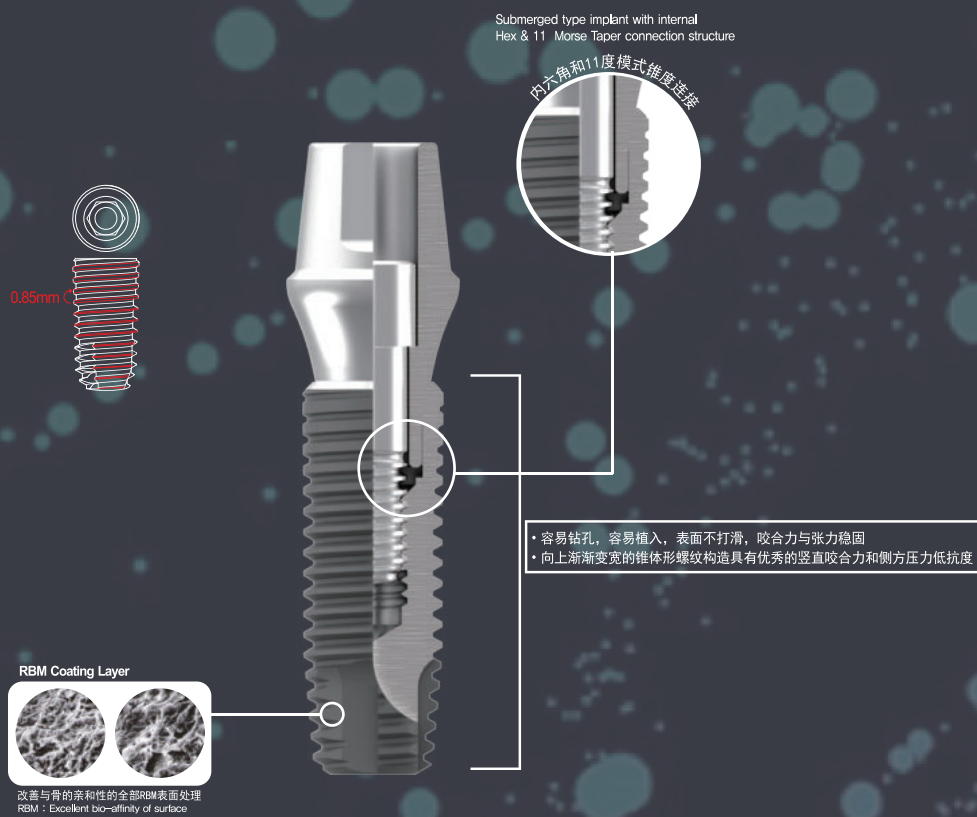

Features of RBM Surface Treatment Layer

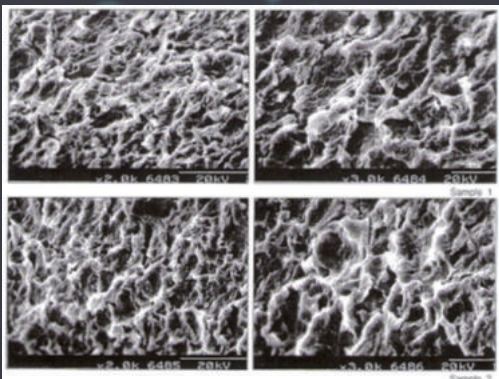

1) 扫描电子显微镜检查法 (SEM)

细胞可以附着的孔隙幅度明显且变宽，约15 μ m 以上。

2) 原子力显微镜 (AFM)

粗糙值为1.11 μ m \pm 0.12 μ m，没有倾斜分布均匀。

3) 表面粗糙度测试 (Ra)

1.11 μ m

4) 能量色散X射线显微分析仪 (EDX)

分析结果为Ti-91.78%，Al-5.52%，V-2.71%。

5) X射线衍射 (XRD)

在40度，38度和35度附近的顶端会出现检体和JCPDF都相似，可以确定结晶上不存在不纯物。

FLOW CHART

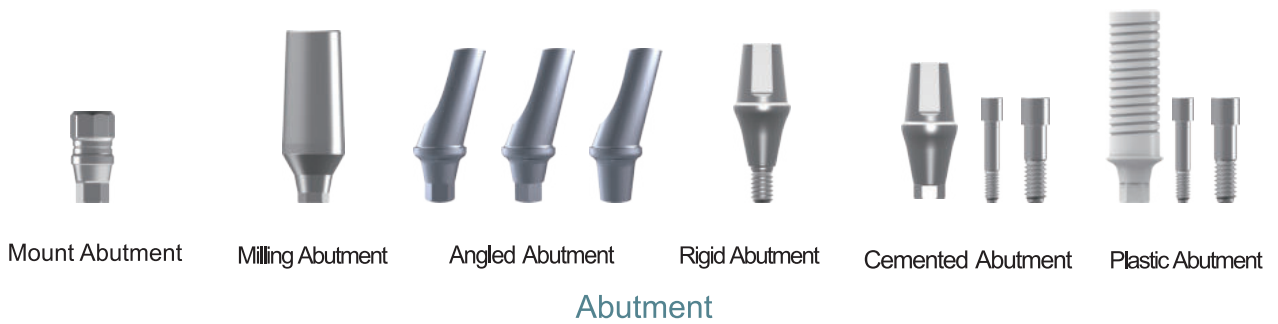
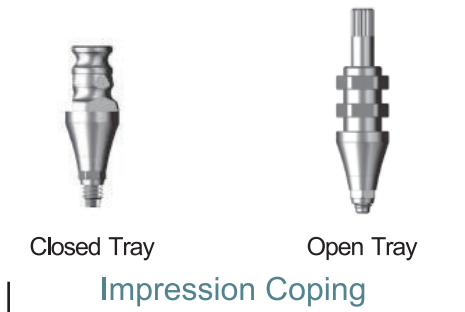

Fixture

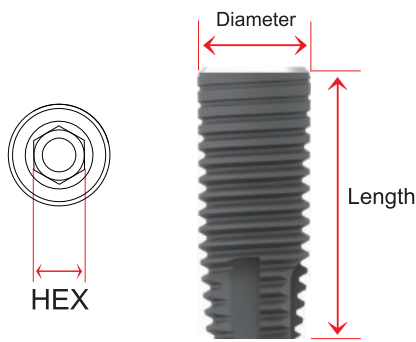

D Diameter \varnothing
L Length
R Order code
GX3508
D L

- Submerged type implant with an Internal Hex & 11' Morse Taper connection structure
- Limited insertion torque : 40Ncm

- 种植体、安置基台、基台螺丝+覆盖螺丝
- 11锥形内接六角连接埋入式种植体
- 锥形体构造具有十分良好的初期固定力
- 骨等级(埋入式)种植体
- 切边具有良好的自攻螺纹能力。
- 限定插入扭矩：40Ncm

Ø3.5



L	8.5mm	10mm	11.5mm	13mm	15mm
R	GX3508	GX3510	GX3511	GX3513	GX3515

Ø4.0



L	8.5mm	10mm	11.5mm	13mm	15mm
R	GX4008	GX4010	GX4011	GX4013	GX4015

Ø4.5



L	8.5mm	10mm	11.5mm	13mm	15mm
R	GX4508	GX4510	GX4511	GX4513	GX4515

Ø5.0



L	8.5mm	10mm	11.5mm	13mm	15mm
R	GX5008	GX5010	GX5011	GX5013	GX5015

Cover Screw

Packing unit : Cover screw

包装单位：覆盖螺丝 (Cover Screw)

- Use 1.2 Hex Drivers
- Tightening torque : 5-8 Ncm

- 使用1.2六角螺丝
- 限定插入扭矩：5-8 Ncm



L
5.8mm

REF
GCSN2858



L
6.55mm

REF
GCSR3865

Healing Abutment

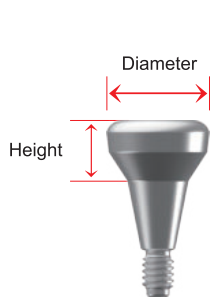

D Diameter \emptyset

H Height

R Oder code

HA5513-M
D H

Packing unit : Healing Abutment

- Use 1,2 Hex Drivers
- Tightening torque : 5-8 Ncm

包装单位：覆盖螺丝 (Healing Abutment)

- 使用1.2六角螺丝
- 限定插入扭矩： 5-8 Ncm

Ø4.5



H	3.0mm	4.0mm	5.0mm	7.0mm
R	HA4513-M	HA4524-M	HA4535-M	HA4537-M

Ø5.5





H	3.0mm	4.0mm	5.0mm	7.0mm
R	HA5513-M	HA5524-M	HA5535-M	HA5537-M

Healing Abutment





Ø4.5



				
H	3.0mm	4.0mm	5.0mm	7.0mm
R	HA4513	HA4524	HA4535	HA4537

Ø5.5



				
H	3.0mm	4.0mm	5.0mm	7.0mm
R	HA5513	HA5524	HA5535	HA5537

Ø6.5



				
H	3.0mm	4.0mm	5.0mm	7.0mm
R	HA6513	HA6524	HA6535	HA6537

Impression Coping

包装单位：螺丝

- 安置基台成为转移体
- 向上部露出3mm



Closed tray  

包装单位：螺丝

- 安置基台成为转移体，
- 向上部露出7mm
- 在同时取得确认位置时使用



Open tray  

Packing unit : Impression Coping body + Guide Pin (Hex)
Triangular arc design improves markability following impression

Closed tray



REF
GXIMCCT-M



REF
GXIMCCT-R

Open tray



REF
GXIMCOT-M



REF
GXIMCOT-R

Analog

包装单位：替代体

- 在操作模型上为患者植入的种植体的替代品

Packing unit : Lab analog

- Oral fixtures are built on the working model





REF
GXLAB-M



REF
GXLAB-R

CCM Abutment

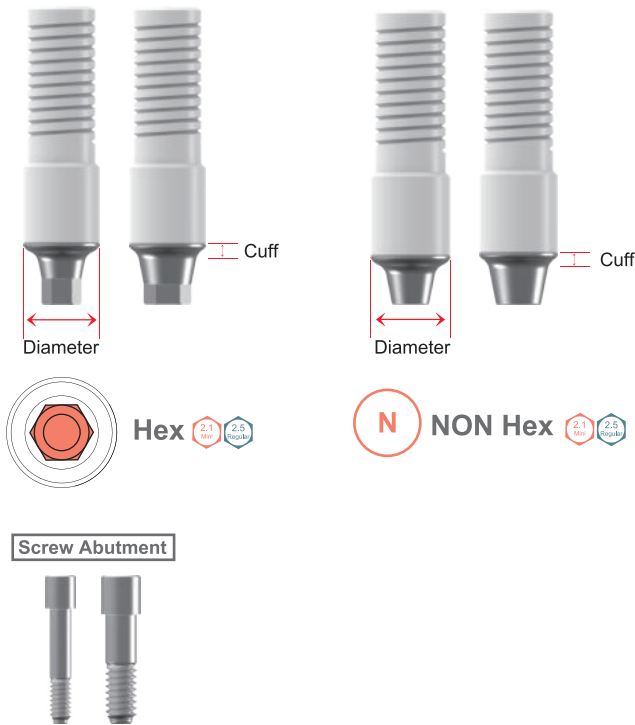

包装单位：基台 + 塑料套管 + 螺丝

- 当路径、高度、空间、美观等受到限制时使用
- 定制型，使用牙科用合金浇筑制作义齿
- 基台 (Co-Cr-Mo Alloy) 熔点1,380 °C ~ 1420 °C
- 使用1.2六角螺丝
- 限定插入扭矩：20Ncm (迷你)，30Ncm (标准)

Packing unit : Abutment + Plastic Sleeve + Abutment screw

- Use for cases with path and aesthetic and spatial constraints
- After customization, be sure to use dental alloy for casting to
- make the prosthesis
- Abutment (Co-Cr-Mo Alloy) melting point 1,380 °C to 1420 °C
- Use a 1.2 Hex Driver
- Tightening torque : NP 20 Ncm, RP 30 Ncm

D Diameter \varnothing
 C Cuff
 R Order code
UA403/N-M
 D C HEX / NonHEX

Ø4.0



C (mm)	1.0mm	3.0mm
REF	UA401-M UA401N-M	UA403-M UA403N-M

Ø4.5



C (mm)	1.0mm	3.0mm
REF	UA451 UA451N	UA453 UA453N

O-ring Abutment

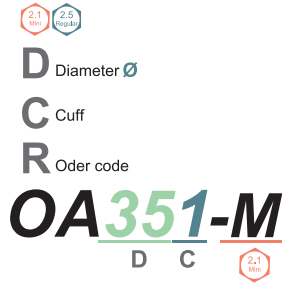
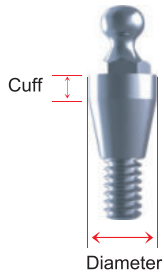

包装单位：基台 + 配件

- 在制作覆盖义齿时使用
- 附件的维系力和安全性良好
- 使用0型螺丝刀 (O Ring Driver)
- 限定插入扭矩：20Ncm (迷你), 30Ncm (标准)

Packing unit : Abutment + O ring Attachment

- Use for making stud-type overdenture
- Superior stability of retention force
- Maximum path compensation of 20
- Use an O – ring abutment Driver
- Tightening torque : NP 20 Ncm, RP 30 Ncm

Ø3.5



C (mm)	1.0mm	2.0mm	3.0mm	4.0mm	5.0mm	6.0mm
REF	OA351-M	OA352-M	OA353-M	OA354-M	OA355-M	OA356-M

Ø3.5



C (mm)	1.0mm	2.0mm	3.0mm	4.0mm	5.0mm	6.0mm
REF	OA351	OA352	OA353	OA354	OA355	OA356

Mount Abutment

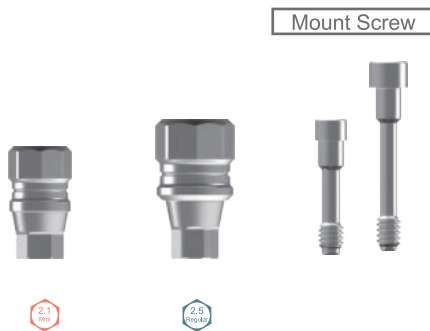

包装单位：基台 + 螺丝

- 可用作印模替代品
- 切除上部，还可用作一般粘结固位基台 (Cement Abutment)。
- 植入种植体时起着适配器 (Adaptor) 的作用。
- 限定插入扭矩：40Ncm (植入种植体时)
- 限定插入扭矩：30Ncm (调节螺丝时)

Packing unit : Abutment+Screw

- Usable for impression substitute
- Usable for general cemented abutment after cutting the top
- Working as an adaptor in implanting
- Torque limit : 40Ncm(implanting fixture)
- Torque limit : 30Ncm(controlling Screw)

Ø2.08



L	REF
11.5mm	GMN4312

Ø2.48



L	REF
11.5mm	GMR4311

Milling Abutment- Two piece

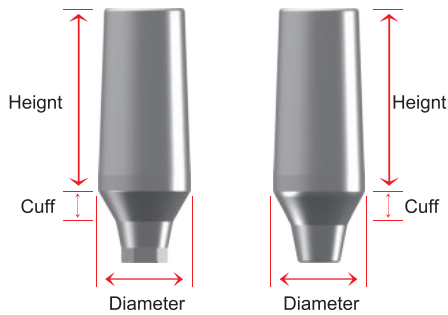

Hex 2.1 Mini 2.5 Regular



N NON Hex 2.1 Mini 2.5 Regular

Packing unit : Cover screw

- Use 1,2 Hex Drivers
- Tightening torque : 5–8 Ncm

包装单位: 覆盖螺丝 (Cover Screw)

- 使用1.2六角螺丝
- 限定插入扭矩: 5-8 Ncm

D Diameter \emptyset

H Height

C Cuff

R Oder code

SA4520H/N
D C HEX / NON HEX

Ø4.0

2.1 Mini	H	1.0mm		
	C(mm)/R	2.0	SA4020H-M	SA4020N-M

Ø4.5

2.5 Regular	H	1.0mm		
	C(mm)/R	2.0	SA4520H	SA4520N

Ø5.5

2.5 Regular	H	1.0mm		
	C(mm)/R	2.0	SA5520H	SA5520N

Ø6.5

2.5 Regular	H	1.0mm		
	C(mm)/R	2.0	SA6520H	SA6520N

Angled Abutment- Two piece

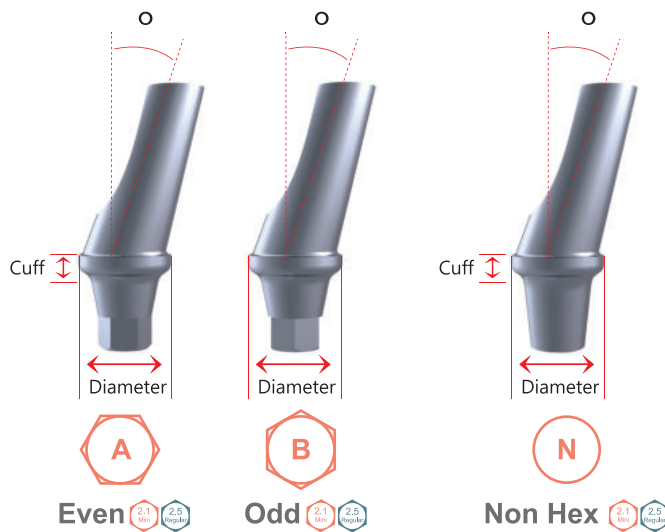

包装单位：角度基台 + 螺丝

- 17度角，当需要调节义齿的路径时使用
- 包括A, B两种六角型，可以进行各种角度调节
- 使用1.2六角螺丝
- 限定插入扭矩：20Ncm(迷你)，30Ncm(标准)

Packing unit : Abutment + Abutment screw

- Use for the path adjustment of prosthesis
- Even / Odd two type hex connection overcoming the limitation of the abutment
- Use a 1,2 Hex Driver
- Tightening torque : NP 20 Ncm, RP 30 Ncm

Screw Abutment



D Diameter \emptyset

C Cuff

○ Angle

R Oder code

AA45215A/B/N-M
D C 15° Even A / Odd B / Non HEX

Ø4.5



C (mm)	2.0		4.0	
°/R 15°	AA42515A-M	AA45215N-M	AA45415A-M	AA45415N-M
	AA45215B-M		AA45415B-M	
25°	AA45225A-M	AA45225N-M	AA45425A-M	AA45425N-M
	AA45225B-M		AA45425B-M	

Ø4.5



C (mm)	2.0		4.0	
°/R 15°	AA45215A	AA45215N	AA45415A	AA45415N
	AA45215B		AA45415B	
25°	AA45225A	AA45225N	AA45425A	AA45425N
	AA45225B		AA45425B	

Ø5.5



C (mm)	2.0		4.0	
°/R 15°	AA55215A	AA55215N	AA55415A	AA55415N
	AA55215B		AA55415B	
25°	AA55225A	AA55225N	AA55425A	AA55425N
	AA55225B		AA55425B	

Rigid Abutment- One Piece

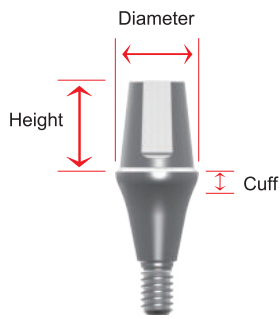

D Diameter \varnothing

H Height

C Cuff

Ref Oder code

GRAN4420
D H C

Packing unit : Abutment+Screw

- Use 1.2 Hex Drivers
- Tightening torque : NP 20 Ncm, RP 30 Ncm

包装单位: 基台 + 螺丝

- 使用1.2六角螺丝
- 限定插入扭矩: 20Ncm(迷你), 30Ncm(标准)

Ø4.0





H	4.0mm	5.5mm	7.0mm
C(mm)/R 2.0	GRAN4420	GRAN4620	GRAN4720
C(mm)/R 3.0	GRAN4430	GRAN4630	GRAN4730

Ø4.0





H	4.0mm	5.5mm	7.0mm
C(mm)/R 2.0	GRA4420	GRA4620	GRA4720
C(mm)/R 3.0	GRA4430	GRA4630	GRA4730

		
H	5.5mm	7.0mm
C(mm)/R	2.0	
	GRA5620	GRA5720

Ø5.0



		
C(mm)/R	3.0	
	GRA5630	GRA5730

			
H	4.0mm	5.5mm	7.0mm
C(mm)/R	2.0		
	GRA6420	GRA6620	GRA6720

Ø6.0



			
C(mm)/R	3.0		
	GRA6430	GRA6630	GRA6730

Cemented Abutment- Two piece

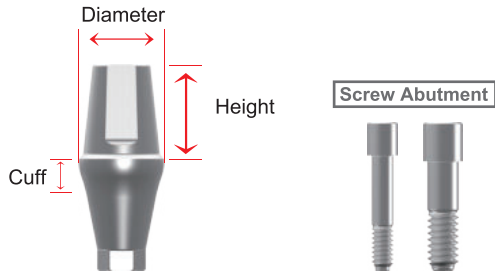

包装单位：基台 + 基台螺丝

- 用于粘结型义齿的制作 • 为防止义齿旋转，进行铣刀加工处理
- 包括六角型和非六角型 • 使用1.2六角螺丝
- 限定插入扭矩：20Ncm (迷你)，30Ncm (标准)

Packing unit : Abutment + Abutment screw

- Use for making general cement-type prosthesis
- Tapered body design facilitating prosthetic fit
- cross-section design for the prevention of prosthesis rotation Use a 1,2 Hex Driver
- Tightening torque : NP 20 Ncm, RP 30 Ncm



D Diameter \varnothing

H Height

C Cuff

R Oder code

GTA45551/N-M
D H C HEX / NonHEX 2.1 Mini

GTA5410/N
D C HEX / NonHEX

Ø4.5



C (mm)	1.0	2.0	3.0	4.0	5.0
H/R 5.5mm	GTA45551-M	GTA45552-M	GTA45553-M	GTA45554-M	GTA50555-M

GTA45551N-M GTA45552N-M GTA45553N-M GTA45554N-M GTA50555N-M

Ø5.0



		1.0	2.0	3.0	4.0
C (mm)					
H/R	5.5mm	GTA5611	GTA5621	GTA5631	GTA5641

Ø5.5



		1.0	2.0	3.0	4.0
C (mm)					
H/R	5.5mm	GTA50551-M GTA50551N-M	GTA50552-M GTA50552N-M	GTA50553-M GTA50553N-M	GTA50554-M GTA50554N-M

Ø4.5







		1.0	2.0	3.0	4.0	5.0
C (mm)						
H/R	4.0mm	GTA45410	GTA45420	GTA45430	GTA45440	GTA45450
		GTA45410N	GTA45420N	GTA45430N	GTA45440N	GTA45450N
5.5mm		GTA45610	GTA45620	GTA45630	GTA45640	GTA45650
		GTA45610N	GTA45620N	GTA45630N	GTA45640N	GTA45650N
7.0mm		GTA45710	GTA45720	GTA45730	GTA45740	GTA45750
		GTA45710N	GTA45720N	GTA45730N	GTA45740N	GTA45750N

Cemented Abutment- Two piece





Ø5.0



						
		1.0	2.0	3.0	4.0	5.0
C (mm)	H/R					
4.0mm		GTA5410	GTA5420	GTA5430	GTA45740	GTA5450
		GTA5410N	GTA5420N	GTA5430N	GTA5440N	GTA5450N
5.5mm		GTA5610	GTA5620	GTA5630	GTA5640	GTA5650
		GTA5610N	GTA5620N	GTA5630N	GTA5640N	GTA5650N
7.0mm		GTA5710	GTA5720	GTA5730	GTA5740	GTA5750
		GTA5710N	GTA5720N	GTA5730N	GTA5740N	GTA5750N

Ø5.5



						
		1.0	2.0	3.0	4.0	5.0
C (mm)	H/R					
4.0mm		GTA55410	GTA55420	GTA55430	GTA55440	GTA55450
		GTA55410N	GTA55420N	GTA55430N	GTA55440N	GTA55450N
5.5mm		GTA55610	GTA55620	GTA55630	GTA55640	GTA55650
		GTA55610N	GTA55620N	GTA55630N	GTA55640N	GTA55650N
7.0mm		GTA55710	GTA55720	GTA55730	GTA55740	GTA55750
		GTA55710N	GTA55720N	GTA55730N	GTA55740N	GTA55750N

Ø6.0



		C (mm)				
		1.0	2.0	3.0	4.0	5.0
H/R	4.0mm	GTA6410	GTA6420	GTA6430	GTA6440	GTA6450
		GTA56410N	GTA6420N	GTA6430N	GTA6440N	GTA6450N
5.5mm		GTA6610	GTA6620	GTA6630	GTA55740	GTA6650
		GTA6610N	GTA6620N	GTA6630N	GTA6640N	GTA6650N

Ø6.5



		C (mm)				
		1.0	2.0	3.0	4.0	5.0
H/R	4.0mm	GTA65410	GTA65420	GTA65430	GTA65440	GTA65450
		GTA65410N	GTA65420N	GTA65430N	GTA65440N	GTA65450N
5.5mm		GTA65610	GTA65620	GTA65630	GTA65640	GTA65650
		GTA65610N	GTA65620N	GTA65630N	GTA65640N	GTA65650N
7.0mm		GTA65710	GTA65720	GTA65730	GTA65740	GTA65750
		GTA65710N	GTA65720N	GTA65730N	GTA65740N	GTA65750N

Plastic Abutment

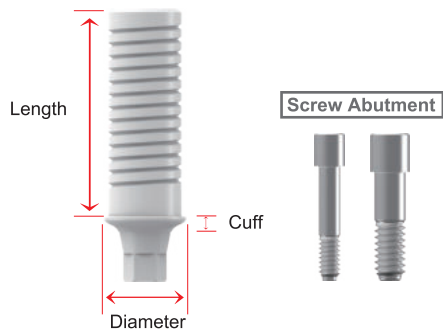

Packing unit : Abutment+Screw

- Use 1,2 Hex Drivers
- Tightening torque : 30 Ncm

包装单位：基台 + 螺丝

- 使用1.2六角螺丝
- 限定插入扭矩：30 Ncm

D Diameter Ø

L Length

C Cuff

R Oder code

GUCLARH

Ø4.5



L 11.4mm
C(mm)/R 1.56 | **GUCLAMIH**

Ø4.5



L 11.65mm
C(mm)/R 1.75 | **GUCLAMINH**

Ø4.5



L 11.5mm
C(mm)/R 2.5 | **GUCLARH**

Ø4.5



L 11.6mm
C(mm)/R 1.9 | **GUCLARNH**

Surgical Kit



Torque Ratchet



Lance Drill



Lindemann Drill



Step Drill

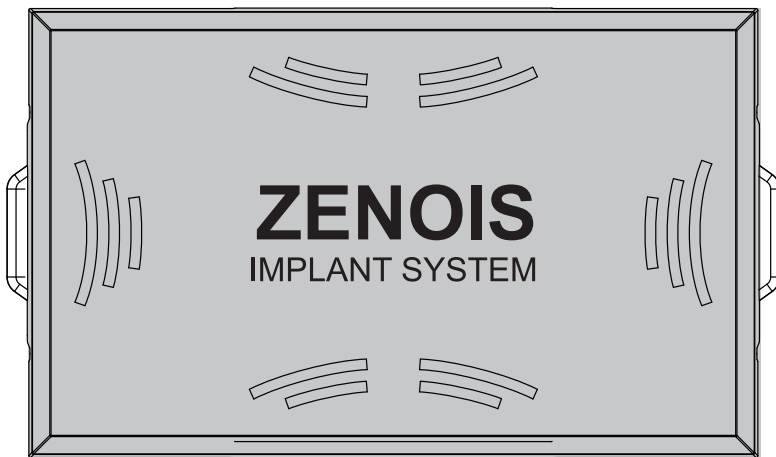

Tissue Punch



Drill

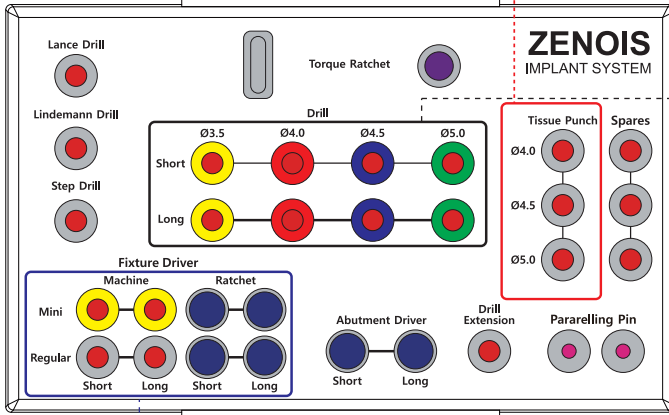

Fixture Driver

Abutment Driver

Driver Extension

Pararelling pin

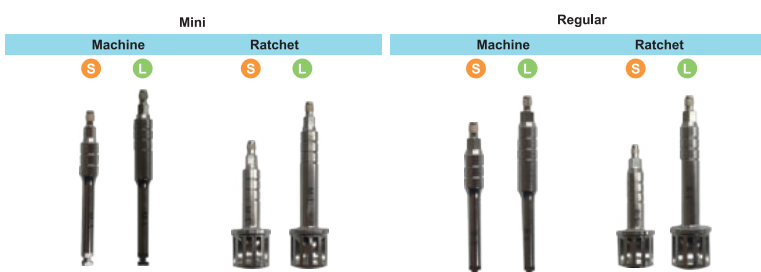

Lance Drill



- 初次钻孔时便于去除皮层骨。
- 可以通过钻孔判断骨密度。
- 手机速度：1,000-1,500 RPM
- Used for first drilling and cutting the bone slightly by 2~3mm
- Deciding the bone density by drilling
- Hand piece speed: 1,000~1,500RPM

Lindemann Drill



- 激光打标，长度可调。(2.0/3.0除外)
- 根据骨密度省略钻孔，容易而迅速。
- 钻头的直径越大，RPM就越小。
- 手机速度：1,000~1,500 RPM
- Laser marking, regulating the length (except for 2,0/3,0)
- Drilling may be optional, depending on the bone density.
- The larger the diameter of drill, the smaller RPM
- Hand Piece speed : 1,000~ 1,500RPM

Step Drill



- 只需一个钻头就可以进行各种深度的钻孔。
- 激光打标，长度可调。
- 钻头的直径越大，RPM就越小。
- 手机速度：1,000~1,500 RPM
- Drilling for various depth with the drill
- Drilling may be optional, depending on the bone density.
- Hand Piece speed : 1,000~ 1,500RPM

Parallel Pin



- 这是分析初期钻孔时形成的孔的状态和设定下次的手术计划的工具。
- 插入2.0的孔中，确认初期钻孔的方向和倾斜度。
- Analyzing the type of hole when it is drilled
- Planning for next surgical procedure
- Inserting into the 2.0 hole,
- Chchecking for the first drilling direction and position

Fixture Driver

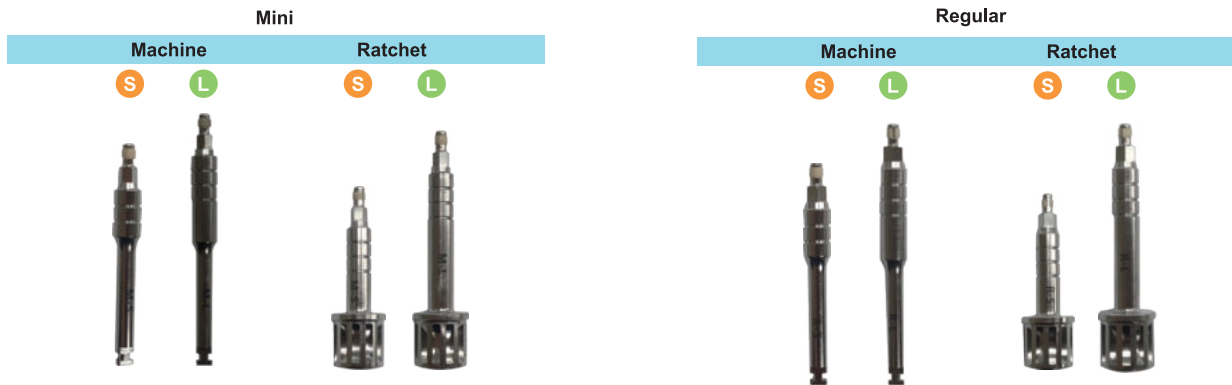

- 包括手机型和扳手型(扭矩螺丝刀)两种，分别有长的和短的类型。
- 扳手型的螺丝刀在螺丝刀与扭矩扳手共同结束植入时使用。
- 手机型在取出种植体和植入初期使用。
- 限定插入扭矩：40Ncm

- Handpiece type & Ratchet type(torque screw driver)
- Long type & short type
- Fixture driver for handpiece : taking out the fixture, in the beginning of implanting
- Torque control : 40Ncm

Abutment Driver



- 在连接基台和基台螺丝刀时使用。
- 扭矩螺丝刀
- 限定插入扭矩：20Ncm(迷你)，30Ncm(标准)

- Using in connecting abutment and abument screw
- Torque screw driver
- Torque control : 20Ncm(mini type), 30Ncm(Standard type)

Drill Extension



- 在延长手机型手术工具的使用长度时使用。
- Extending the length of surgical kit for handpiece type

Tissue Punch



Ø4.0



Ø4.5



Ø5.0

- 选择合适的尺寸。
- 用于取出牙槽骨里面的残留物。
- Choose the right size. Used to remove
- residues from alveolar bone.

Torque Ratchet



- 在连接扭矩螺丝刀时使用。
- 激光标记包括15, 25, 35 Ncm, 可以通过调节力度来使用。
- 增加扭矩的方向须与箭头方向一致。
- Connecting torque screw driver
- Laser marking(15,25,35Ncm)
- Controlling the force

ZENOIS KIT User

Drill Sequence for ZENOIS IMPLANT SYSTEM

RBM Surface Treatment

●> Ø3.5mm Fixture

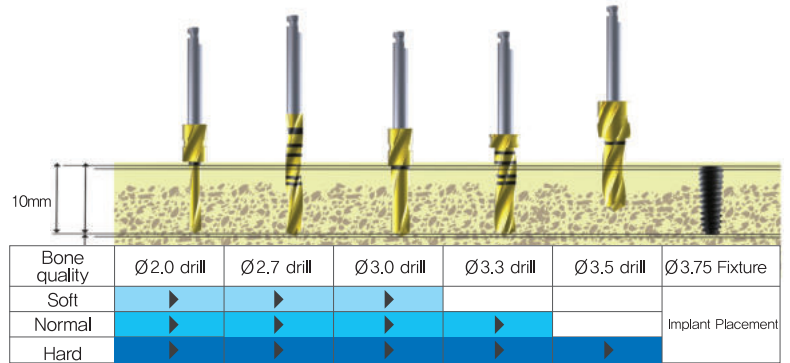

●> Ø4.0mm Fixture

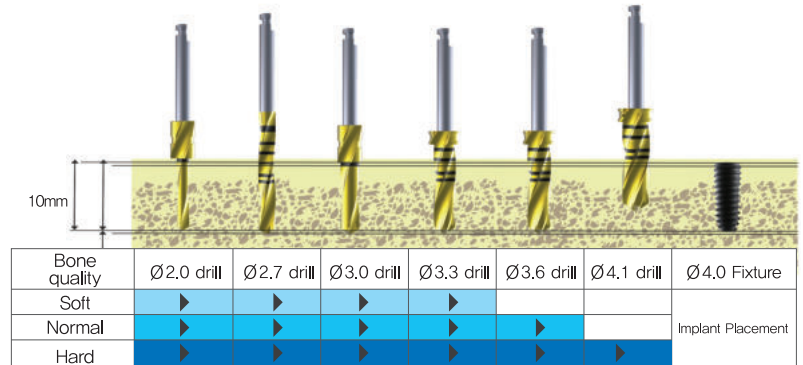

●> Ø4.5mm Fixture

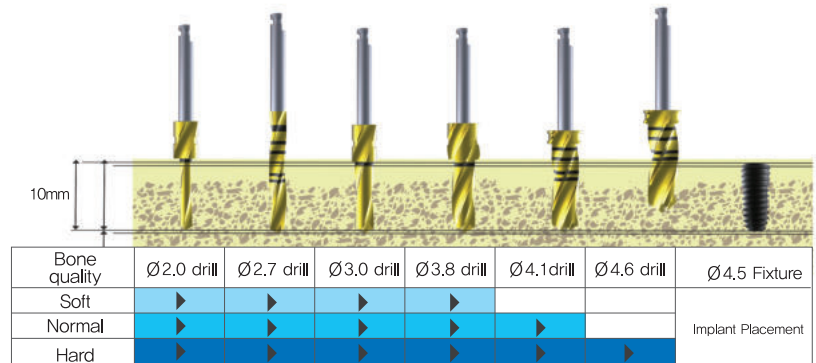

●> Ø5.0mm Fixture

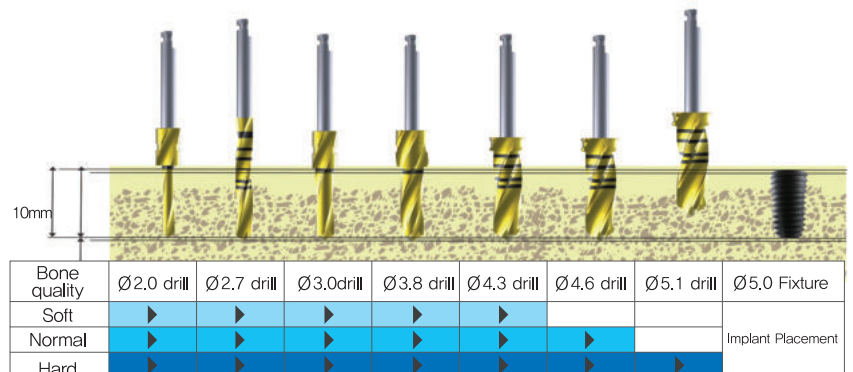

Surgical Procedure

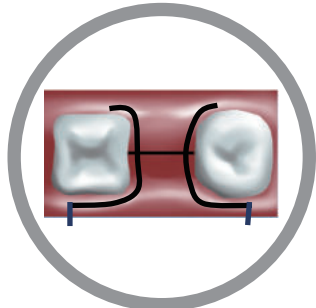

1. 在牙龈顶端切开一个H开口。
Cutting the mucous membrane of gum in H shape

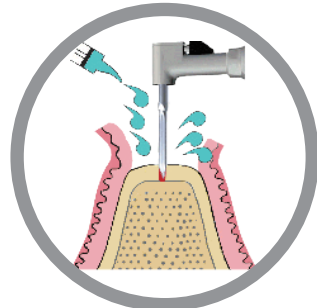

2. 使用 Lance drill在1,000-1,500rpm转速下注塑时, 用深度2-3 mm 表示出植入位置。
Drilling with lance drill with the speed of 1,000 ~ 1,500RPM, marking in the implanting site by 2~3mm deep

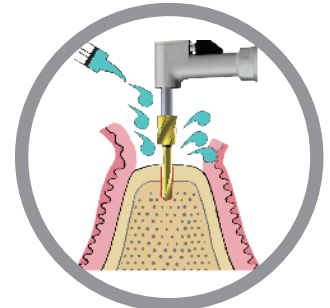

3. 使用 Lindemann Drill 在1,000-1,500rpm的转速下注塑, 钻孔至深度5-6mm。
Using lindemann drill with 1,000~1,500rpm drilling 5-6mm deep

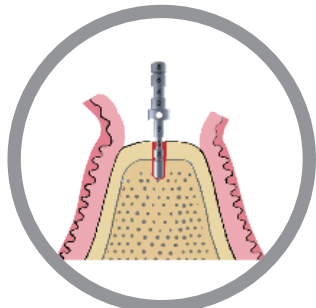

4. 在Pararelling Pin 0侧置入齿槽, 确认是否与邻接牙齿平衡。
Inserting Pararelling pin, checking the parallel with abutting teeth

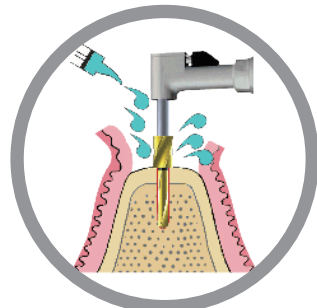

5. 使用 Lindemann Drill 在1,000-1,500rpm的转速下注塑, 同时钻孔直至Lindemann 所在的深度。
Using lindemann drill with 1,000~1,500rpm drilling into the stopper mark

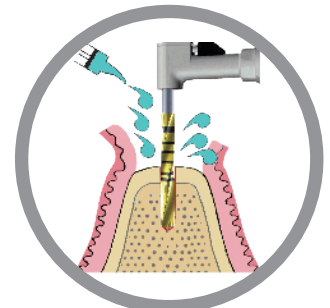

6. 使用 Step Drill 在1,000-1,500rpm 转速下注塑, 同时钻孔至 9和11mm分界线之间。钻孔直至11mm分界线。
Using step drill with 1,000~1,500rpm drilling into the range of 9mm & 11mm

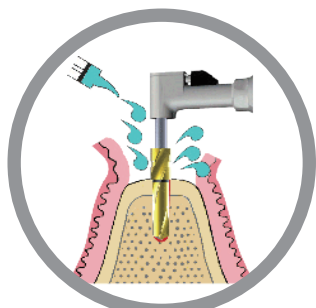

7. 使用 $\Phi 3.5$ Drill在1,000-1,500rpm的转速下注塑, 同时钻孔直至 Stopper 所在的深度。
Using drill (3.5) with 1,000~1,500rpm drilling into the stopper mark

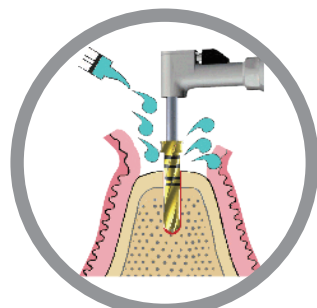

8. 使用 Drill在1,000-1,500rpm的转速下注塑, 钻孔直至9和11mm分界线。钻孔直至11mm分界线。
Using drill with 1,000~1,500rpm drilling into the range of 9mm & 11mm

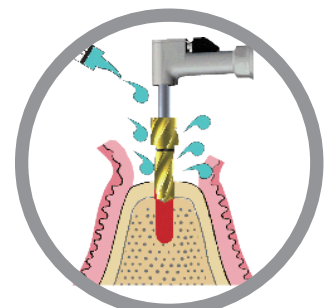

9. 在Hard Bone附近使用 Drill在1,000~1,500rpm的转速下注塑, 以Counter Sink的概念钻孔至4~5mm左右。
In the hard bone, using drill with 1,000~1,500rpm drilling by 4~5mm like counter sink

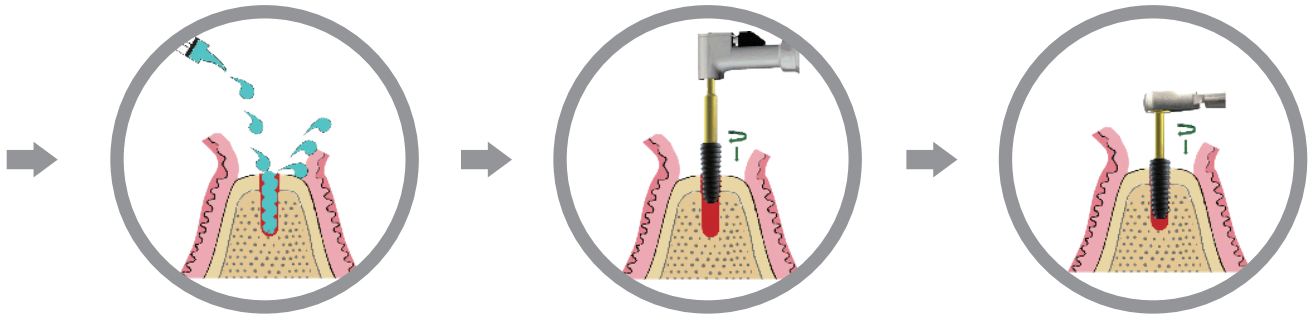

10. 使用盐水清洗完成的齿槽骨。
Clean the finished alveolar bone with saline solution

11. 使用Handpiece用Hex driver在30rpm的转速下植入Fixture至 2/3。
Using a hex driver of handpiece type and implant a fixture with the speed of 30RPM hex driver of handpiece type

12. 使用Torque Ratchet和 Hex driver, 在小于35N/cm的力量下植入 Fixture, 并使顶端与齿槽骨顶端一致。
With the force of less than 35N/cm, implanting a fixture by using Torque Ratchet and Hex driver, the implantation should be matched to the top of alveolar bone

